

Doufit TR-06 Trampoline Instruction Manual (12FT)

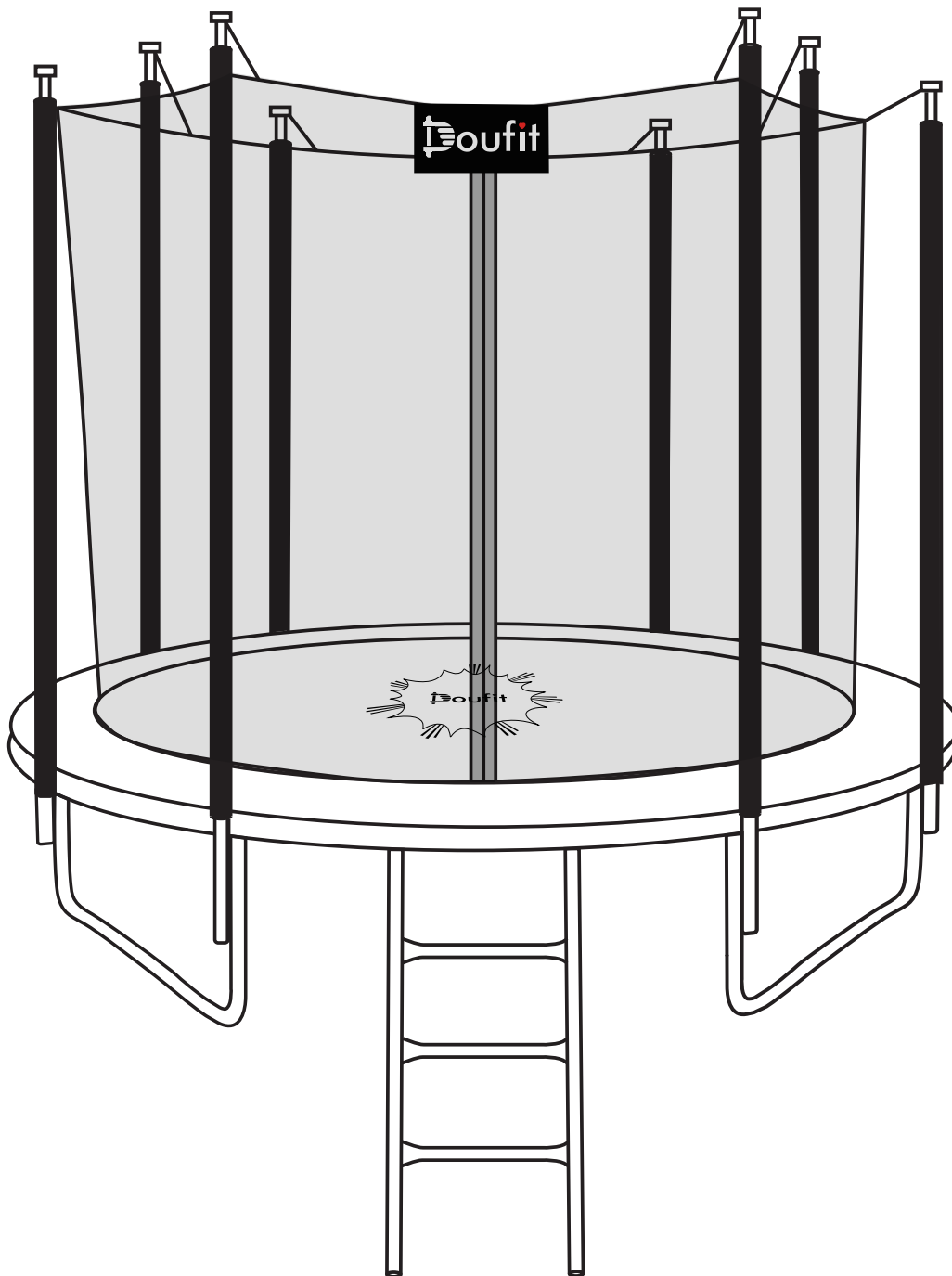

- * Please read the instruction manual carefully and follow it.
- * Please keep the instruction manual for your later use.
- * If you want to give this product to your friends, don't forget to bring them the instruction manual.

Catalogue













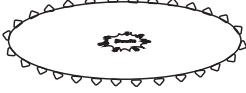

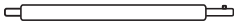
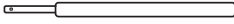
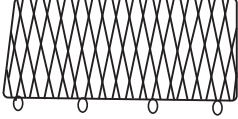
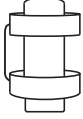
Precautions-----	1
Parts List -----	2
Assembly Method-----	3
Jumping Exercise -----	7
Service -----	8

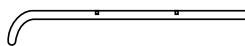
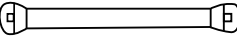
Precautions

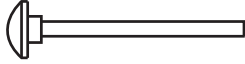
- *The maximum weight capacity is 425 Lbs.
- *The product must be assembled carefully by 2 adults.
- *Place the trampoline on a flat, large and soft place to use, not concrete, asphalt, or any hard coating to prevent slipping when jumping.
- *Before exercise, please take off your valuable accessories, such as glasses, necklaces and watch, to avoid falling.
- *Don't put anything in your pocket or on the trampoline during use.
- *Don't use it during smoking or after drinking.
- *Don't jump indoor or under low trees.
- *The trampoline must be used in good weather.
- *MATS and nets will age prematurely under the long-term direct sunlight. Please store the mat and net indoors If it snows, rains or winds to prevent premature aging.
- *Don't wear clothes with hooks and shoes during use.
- *Close the door on the net before using.
- *Please jump near the central area. Do not walk on the spring pad or the springs.
- *Keep the jumping mat and the spring pad dry.
- *Please exercise in a well-lighted place.
- *Don't jump from the outside or high place to the trampoline.
- *Don't place anything obstacles under the trampoline.
- *Don't somersault or other dangerous jumps. Or you may be paralyzed or even death if landing with the head or neck!
- *For children, they can only use it under the supervision.
- *The trampoline can't be used as a jumping board.
- *Rest after a moderate jumping. Jumping for a long time will increase the risk of injury.
- *Be sure whether the trampoline is loosen, worn, damaged or missing parts before each use.
- *Please clean it with a wet cloth, do not use corrosive solvent cleaners and abrasive products.
- *Don't use this trampoline if you have any conditions or diseases as follows:
 - Pregnancy;
 - Breathing obstacle;
 - Spinal injury, cerebral sclerosis, or acutely swollen joints;
 - Osteoporosis, Gout, unhealed fractures or surgically implanted orthopedic supports;
 - Hypertension, heart disease, or using a cardiac pacemaker;
 - Using anti-coagulants in high doses.

Parts List

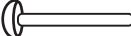
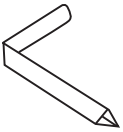
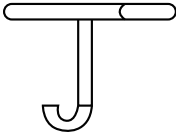
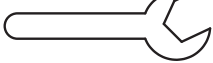
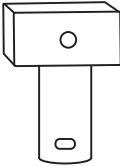
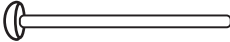
Notice: if any part is missing, distorted or broken when you receive the package, please contact service@doufit.net with your order number, we will send the replacement part to you as soon as possible.

 1.Foot pipe x 4	 2.Leg pipe x 8	 3.Frame pipe x 8	 4.Jumping mat	 5.Spring x 72
 6.Spring pad	 7.Upper support pipe x 8	 8.Lower support pipe x 8	 9.Net	 10.Top cap x 8 (On upper support pipes)
 11.Rope	 12.Ladder frame x 2	 13.Step pipe x 3	 14.M6 10mm bolt x 8	 15.M6 * 78mm carriage bolt x 16
 16.Bracket x 16	 17.M6 washer x 28	 18.M6 lock nut x 30	 19.M6 * 35mm bolt x 6	 20.Allen wrench
 21.Spring hook	 22.Open end wrench	 23.Frame joint x 8	 24.M6*48mm bolt x 8	 25.M6 flat washer x 8

All parts in this package are listed as above.

The rope(No.11), eight M6 lock nuts(No.18), the hook(No.21), all frame joints(No.23), all M6*48mm bolts(No.24), and all M6 flat washers(No.25) are packed in the package of the instruction manual.

Assembly Method



For the assembly video, please visit:
www.youtube.com/channel/UCorBKk34KZgI96OyGskjFdA

Step 1: Assemble the foot pipes

For the step, please prepare four foot pipes(No.1), eight leg pipes(No.2), eight M6*10mm bolts(No.14) and the Allen wrench(No.20).

Connect eight leg pipes to four foot pipes. And then screw eight M6*10mm bolt by using the Allen wrench.

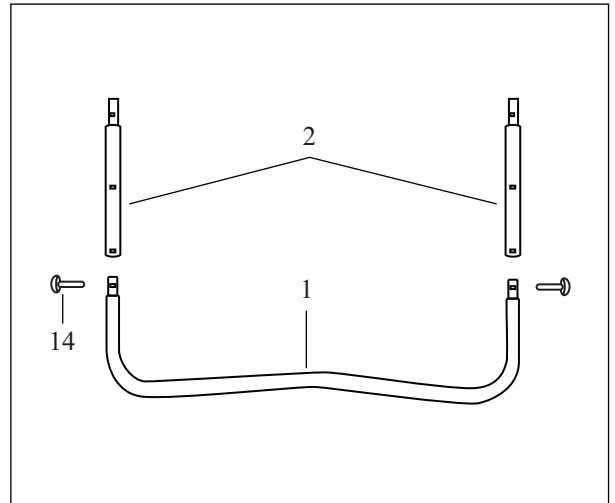

Step 2: Assemble the frame pipes

For this step, please prepare eight frame pipes(No.3), eight M6 lock nuts(No.18), two wrenches(No.20)(No.22), eight frame joints(No.23), eight M6*48mm bolts(No.24), and eight M6 flat washers(No.25).

Attach a frame joint to the bigger side of the frame pipe. Connect the smaller side of the second frame pipe. Insert a M6*48mm bolt from the outside of the frame joint. Screw a M6 flat washers and a M6 lock nut to fix. Connect other frame pipes as above.

For the last connection, please place one side against the wall. And then try your best to press frame pipes of the other side inward, so that the frame can be connected well.

And then attach three foot pipe assemblies to the frame.

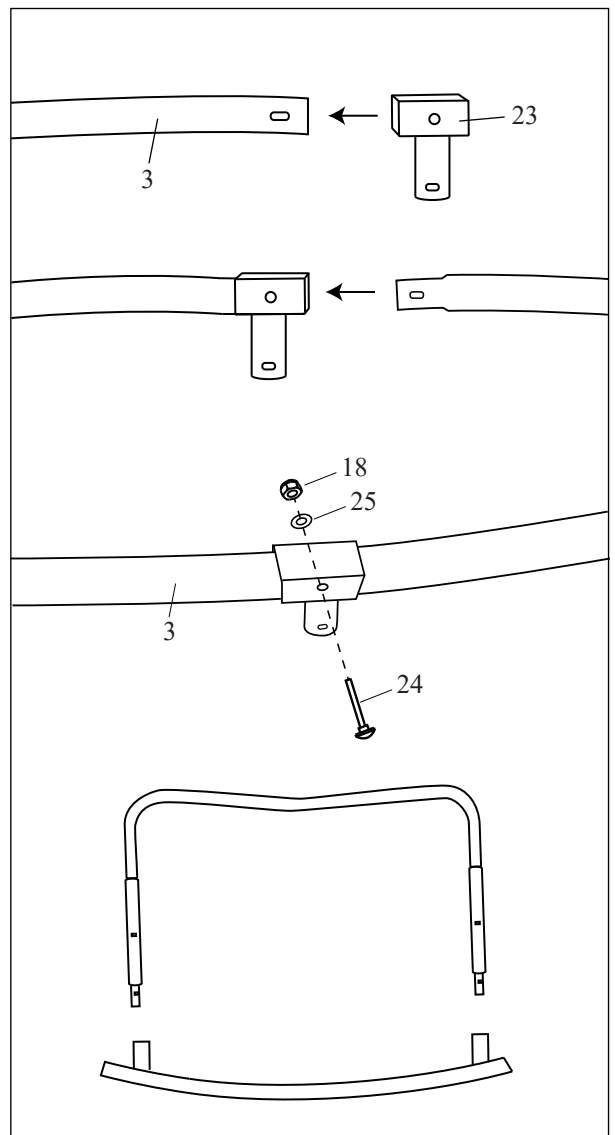

Step 3: Assemble the jumping mat

Attention: Two hooks of the spring(No.5) are different. The more curved hook should be attached to the jumping mat(No.4), while another side should be attached to the frame.

You need to attach the springs by using the spring hook as follows, or it will be difficult to finish.

Firstly, attach a spring every 10 holes.

Secondly, attach a spring every 5 holes.

Thirdly, attach a spring every 2 holes.

Finally, attach the remaining springs to the remaining holes.

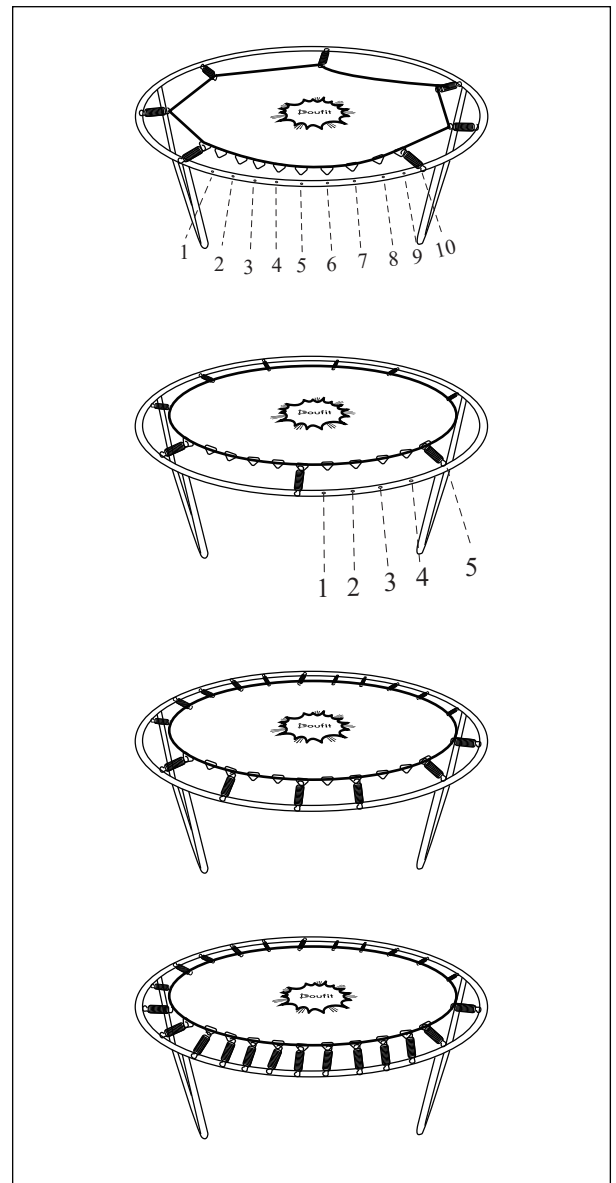
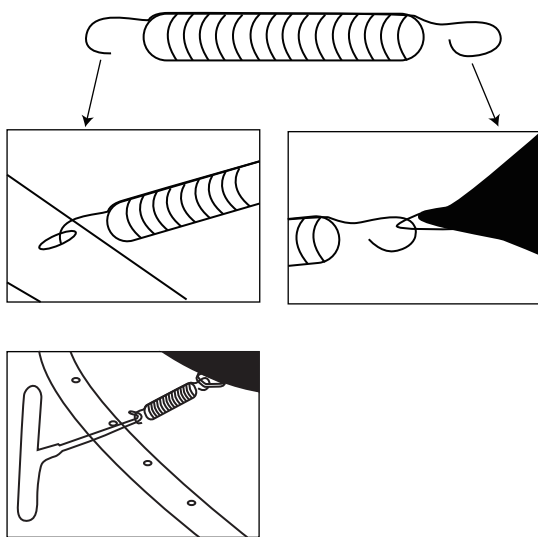

Step 4: Assemble the spring pad

Cover the spring pad(No.6) on the springs. And then tie the rope under the mat.

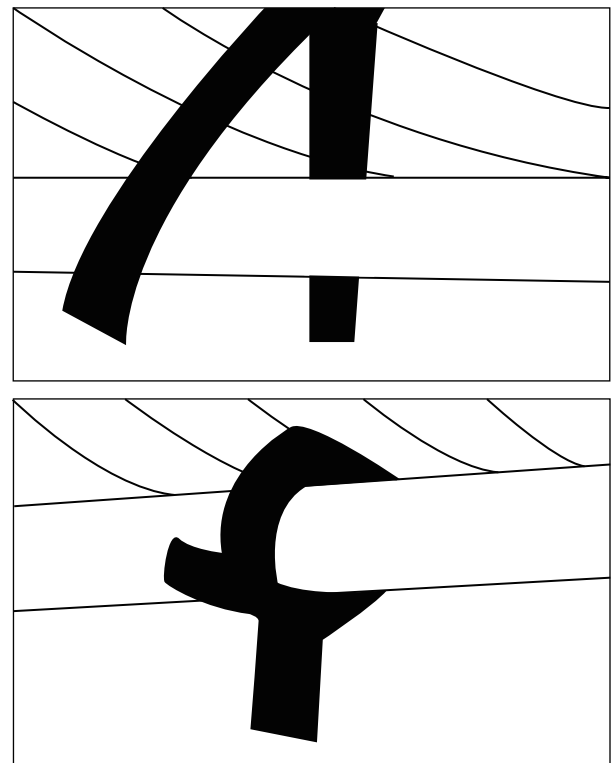
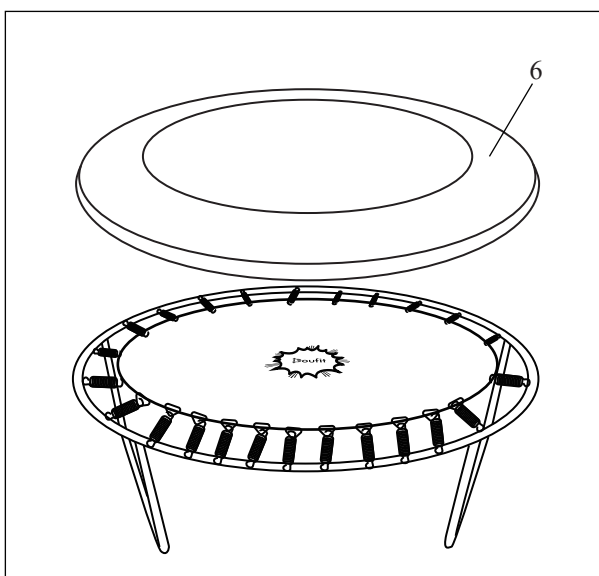

Step 5: Assemble the support pipes

For this step, please prepare eight upper support pipe(No.7), eight lower support pipes(No.8), sixteen M6*78mm carriage bolts(No.15), sixteen brackets(No.16), sixteen washers(No.17), sixteen M6 lock nuts(No.18) and two wrenches(No.20)(No.22).

Attention: The lower support pipe has two holes on one side, while the upper support pipe doesn't have.

Insert an below support pipes to each upper support pipe. Attach eight support pipe assembly and sixteen brackets to the frame. And then screw sixteen M6*78mm carriage bolt, sixteen washers and sixteen M6 lock nuts by using two wrenches.

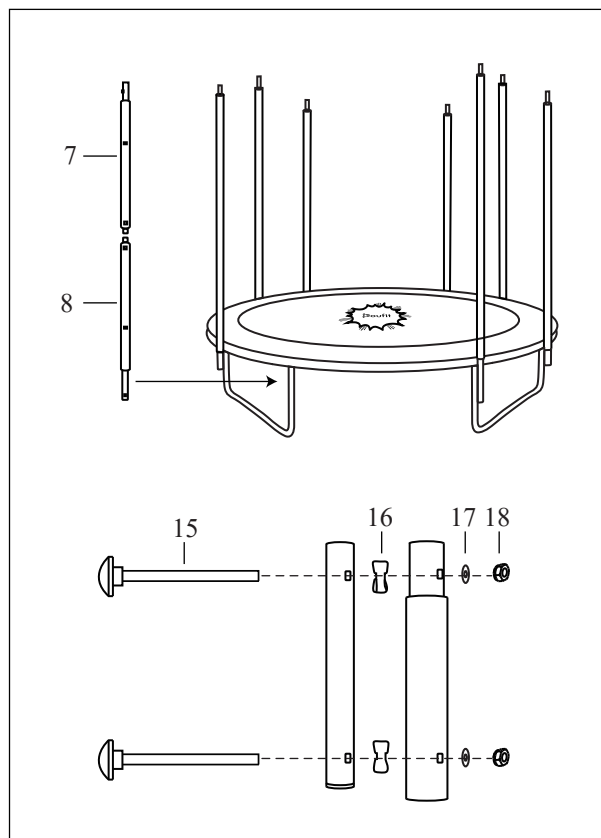

Step 6: Assemble the net

There are eight bands on the net. Insert eight bands through eight top caps(No.10) on upper support pipes. Attach eight plugs to eight bands. Insert the plugs to the sockets.

Align the connecting holes of the net to the triangular rings of the jumping mat. Insert a rope(No.11) through the connecting holes and the triangular rings.

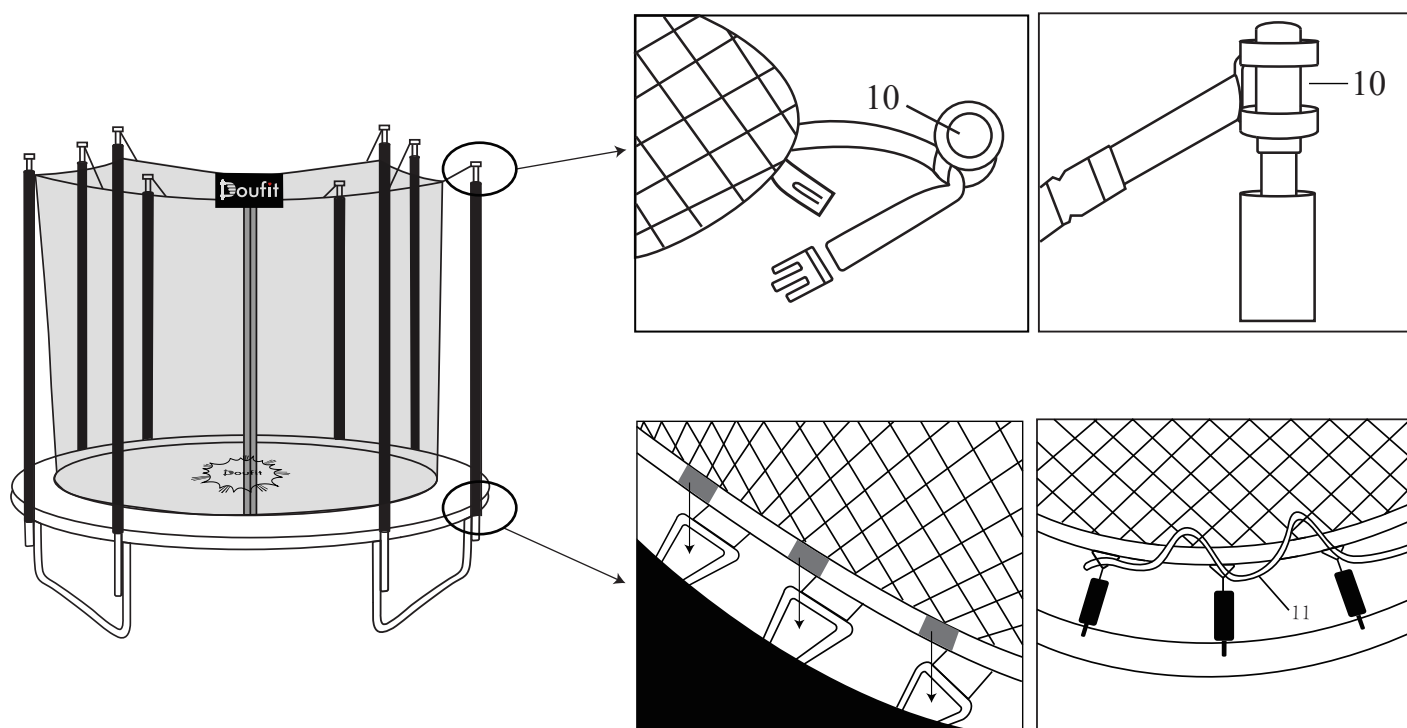

Step 7: Assemble the ladder

For this step, please prepare two ladder frames(No.12), three step pipes(No.13), twelve M6 washers(No.17), six M6 lock nuts(No.18), six M6*35mm bolts(No.19) and two wrenches(No.20)(No.22).

Attach three step pipes to two frame pipes. And the screw six M6*35mm bolts, twelve M6 washers and six M6 lock nut by using two wrenches.

Finally hook the ladder to the frame.

Attention:

Please place the trampoline on a flat ground to use, otherwise, it will shorten the life of the trampoline;

After assembly, please do not drag the trampoline; If you must move it, please re-adjust the trampoline after moving. You can only use it again after you confirming that all of the legs of the trampoline are perpendicular to the ground, otherwise, the trampoline will tilt or even collapse.

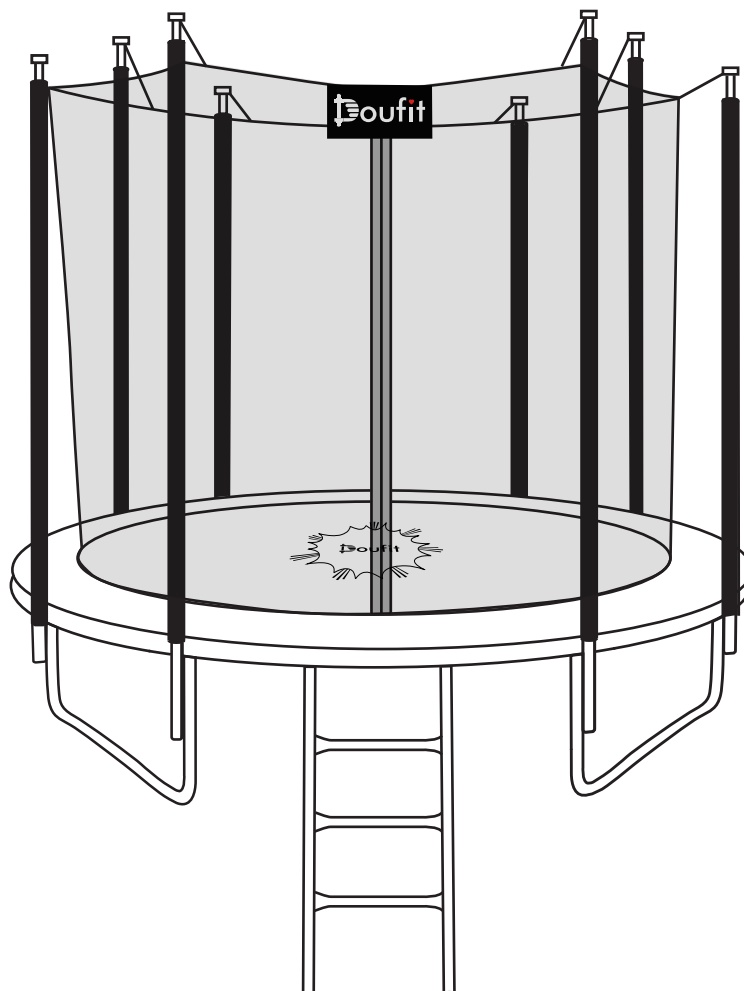
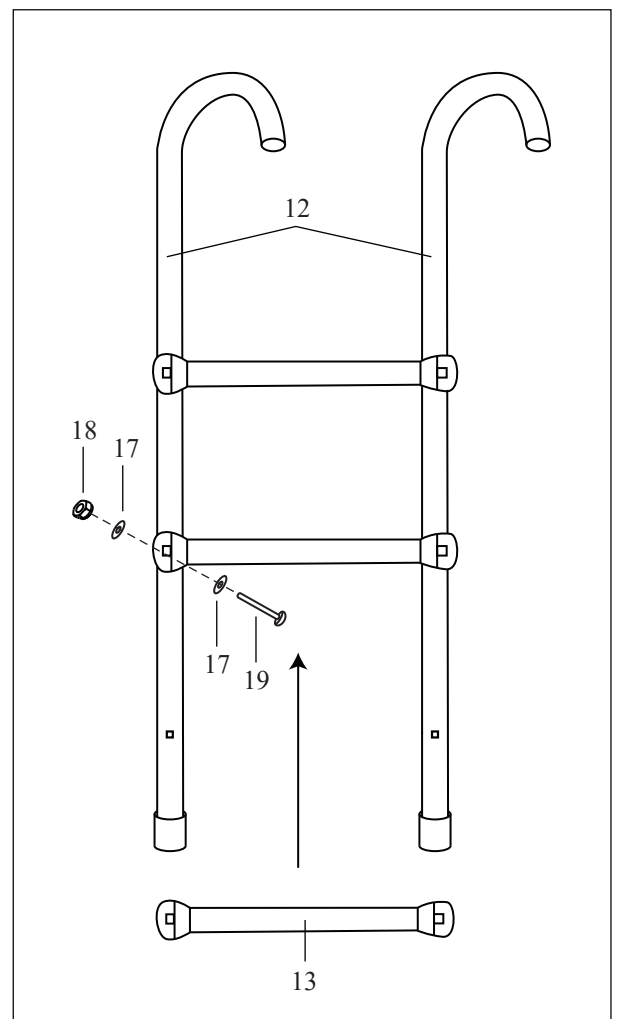

Jumping Exercise

Users must always follow the following instructions :

- When using the trampoline for the first time, you must concentrate on learning how to control jumps rather than on your jumping height.
- Beginners should wear suitable protective sport clothing to protect their elbows and knees.
- As a safety measure, you must first learn how to decelerate and stop jumping as soon as you start to lose control, by bending the knees when landing.
- When your jumping is well controlled, you will land at the center of the trampoline.
- You must practice and improve the basic skills and never attempt a more difficult exercise until you have mastered all the exercises learned previously.

STRAIGHT JUMP



- 1) Stand in the center of the jumping mat. Keep your legs slightly apart and arms by your sides.
- 2) Perform a half squat while driving your arms rearward.
- 3) Drive your arms upwards in a circular movement and jump straight up.
- 4) As you enter mid-air, point your toes downwards. When landing on the jumping mat, your feet are flat and slightly apart.

SPLIT JUMP



- 1) Stand in the center of the jumping mat. Keep your feet together and your arms by your sides.
- 2) Perform a half squat while driving your arms rearward.
- 3) Jump upward as powerfully as you can. As you enter mid-air, bring one leg forward and the other rearward. Point your toes.
- 4) As you begin to drop, put your legs back together and bend your knees to land.

STRADDLE JUMP

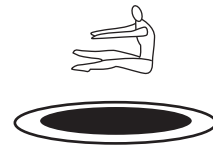

- 1) Stand in the center of the jumping mat. Keep your legs slightly apart and arms by your sides.
- 2) Perform a half squat while driving your arms rearward.
- 3) Jump upward as powerfully as you can. As you enter mid-air, bring your legs out to the sides and point your toes out, and stretch your arms out toward your pointed toes.
- 4) As you begin to drop, put your legs back together and bend your knees to land.

PIKE JUMP



- 1) Stand in the center of the jumping mat.
- 2) Jump straight up.
- 3) As you enter mid-air, bring your legs up and toes pointing forward.
- 4) As you begin to drop, put your legs back together and bend your knees to land.

BACK DROP



- 1) Stand in the center of the jumping mat.
- 2) Jump straight up.
- 3) As you enter mid-air, bring your legs up and keep your back under you.
- 4) When rebounding, keep your legs down and try stand back as you can.

EXTENSION JUMP



- 1) Stand in the center of the jumping mat.
- 2) Jump straight up.
- 3) Extend your body as you can in mid-air .
- 5) As you begin to drop, put your legs back together and bend your knees to land.

TUCK JUMP



- 1) Stand in the center of the jumping mat. Keep your legs shoulder-width apart and arms by your sides.
- 2) Perform a half squat while driving your arms rearward.
- 3) Jump upward as powerfully as you can. As you enter mid-air, bring your knees up to your chest and wrap them with your hands.
- 4) As you begin to drop, release your legs and bend your knees to land.

FRONT DROP



- 1) Stand in the center of the jumping mat.
- 2) Jump straight up and push your hips backwards slightly to make your body flat in mid-air.
- 3) As you begin to drop, bend your arms into a diamond shape in front of your face for protection.

HANDS AND KNEES DROPS



- 1) Stand in the center of the jumping mat.
- 2) Jump straight up and push your hips backwards slightly to make you facing the mat.
- 3) As you enter mid-air, kneel and put your arms down to drop and rebound.

KNEE DROP



- 1) Stand in the center of the jumping mat.
- 2) Jump straight up.
- 3) As you enter mid-air, kneel to drop and rebound.

TWIST



- 1) Stand in the center of the jumping mat.
- 2) Twist your body when you jump.

SEAT DROP



- 1) Stand in the center of the jumping mat.
- 2) Jump straight up.
- 3) Bring your legs forward. Keep your arms back and fingers forward.
- 4) When landing, push downward with your arms to get back up.

Service

If you have any question or problem, please contact our service@doufit.net with your order number, then we will try our best to solve it for you ASAP.



service@doufit.net

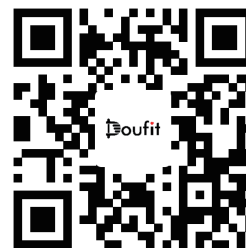

www.doufit.net